



Program Bulletin



CUSTOMER SATISFACTION PROGRAM

SUBJECT: PAINTED ROOF ADHESIVE SEPARATION

**MODELS: 2005-2006 CHEVROLET CORVETTE
WITH PAINTED ROOF**

This bulletin is being revised to include Z06 vehicles. A new procedure and labor time have been added. Discard all copies of bulletin 05112C, issued June 2006.

THIS PROGRAM IS IN EFFECT UNTIL MARCH 31, 2007.

CONDITION

On **certain** 2005-2006 Chevrolet Corvette vehicles, the painted roof panel may separate from its frame in some areas if it is exposed to stresses along with high temperature and humidity. The occupants of the vehicle may notice one or more of these symptoms: a snapping noise when driving over bumps, wind noise, poor roof panel fit, roof panel movement/bounce when a door or hatch is closed, or a water leak in the headliner.

CORRECTION

Dealers are to apply adhesive foam to ensure proper adhesion, or in a small number of vehicles, replace the roof panel.

VEHICLES INVOLVED

Involved are **certain** 2005-2006 Chevrolet Corvette vehicles with a painted roof, and built within these VIN breakpoints:

YEAR	DIVISION	MODEL	FROM	THROUGH
2005	Chevrolet	Corvette	55100002	55135053
2006	Chevrolet	Corvette	65100001	65131106

IMPORTANT: Dealers should confirm vehicle eligibility through **GMVIS** (GM Vehicle Inquiry System) prior to beginning program repairs. [Not all vehicles within the above breakpoints may be involved.]

For US and Canada: For GM dealers, Canadian Saab, and Canadian Saturn retailers with involved vehicles, a Campaign Initiation Detail Report (CIDR) containing the complete vehicle identification number, customer name and address data has been prepared and will be loaded to the GM DealerWorld (US) Recall Information, GMinfoNet (Canada) Recall Reports. For US Saturn retailers only, the involved vehicles are provided in a Facility VIN List file sent to you at your current email address. Dealers/retailers will not have a report available if they have no involved vehicles currently assigned.

For Export: For dealers with involved vehicles, a Campaign Initiation Detail Report containing the complete vehicle identification number, customer name and address data has been prepared, and is being furnished to involved dealers. Dealers will not receive a report with the bulletin if they have no involved vehicles currently assigned.

The Campaign Initiation Detail Report may contain customer names and addresses obtained from Motor Vehicle Registration Records. The use of such motor vehicle registration data for any purpose other than follow-up necessary to complete this program is a violation of law in several states/provinces/countries. Accordingly, you are urged to limit the use of this report to the follow-up necessary to complete this program.

PARTS INFORMATION

Parts required to complete this program are to be obtained from General Motors Service Parts Operations (GMSPO). Please refer to your "involved vehicles listing" before ordering parts. Normal orders should be placed on a DRO = Daily Replenishment Order. In an emergency situation, parts should be ordered on a CSO = Customer Special Order.

Part Number	Description	Quantity/Vehicle
88861400	Adhesive Kit-Foam	2 (Coupe) 1 (Z06 Coupe)
11561612	Roof Panel Fasteners (Z06 Coupe)	1 Package

SPECIAL TOOL

Beginning the week of February 13, 2006, each dealer was shipped a Two-Part Adhesive Applicator Gun, BO 48206, for use in this recall. This tool was furnished at no charge. Additional tools, if required, may be purchased by contacting SPX Kent-Moore at 1-800-468-6657.

SERVICE PROCEDURE

Inspection Procedure - Z06 Coupe

1. Remove the driver and passenger side sun visor and sun visor clamp. Refer to the *Sun Shade Replacement* procedure in SI.
2. Disconnect the rear view mirror electrical connector. Refer to the *Rear View Mirror Replacement* procedure in SI.
3. Remove the windshield side garnish molding. Refer to the *Windshield Side Garnish Molding Replacement* procedure in SI.

Important: The rear roof bow trim panel holds the rear of the headliner in place.

4. Remove the rear roof bow trim panel. Refer to the *Rear Roof Bow Trim Panel Replacement* procedure in SI.



1832869

5. Remove the headliner from the vehicle
 - 5.1 Ensure that the sunshade and rear view mirror electrical connectors have been disconnected.
 - 5.2 Pry down on the edge of the headliner to loosen it from the vehicle roof panel.
 - 5.3 Lower the headliner and route it through the rear hatch.
6. Remove the bolts on all four corners of the roof panel and the center rear bracket.
7. Remove the roof panel from the vehicle. Discard the 10 roof panel fasteners.



1832871

Important: Note the orientation and number of shims on the driver and passenger side of the roof panel assembly contact points and the center rear bracket.

Notice: Protect the painted surface of the roof panel from damage.

8. Place the roof panel, painted surface down, on a glass stand, bench, or other suitable area.

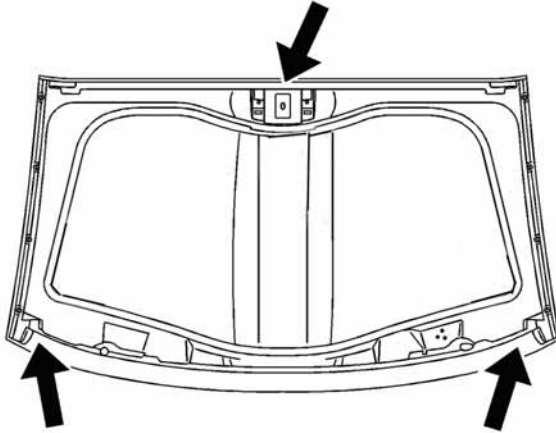

1841578

9. Inspect for proper adhesion by inserting a 0.254 mm (.010 in) feeler gage between the panel and the frame. If the feeler gage fits between the panel and the frame, and the depth is 19.05 mm (.750 in) or greater, the roof panel is separated from the frame.
- If the feeler gage does not identify any area of the roof panel with separation, proceed to Step 4.

- If less than 75 percent of the roof panel is separated from the frame, prepare the roof panel for the foam adhesive injection procedure. Refer to the section titled, *Roof Panel Preparation for Roof Panels with Separation*. This is a temporary repair that will prevent the separation of the roof panel. Submit the claim using labor code T5461, which will not close the program in GMVIS. When the roof panel is available, install the new roof panel and submit the claim using the appropriate V labor code, which will close the program in GMVIS.

Important: Inspect all roof panels, including new roof panels, to determine if the foam fill procedure has been completed. Perform the foam adhesive injection procedure on all new roof panels that have not been foam filled. Perform Steps 4-22 after removing the original roof panel.

- If more than 75 percent of the roof panel is separated from the frame, replace the roof panel.

Roof Panel Preparation for Roof Panels with Separation - Z06

1. Mark the gaps or separation of the roof panel with tape.

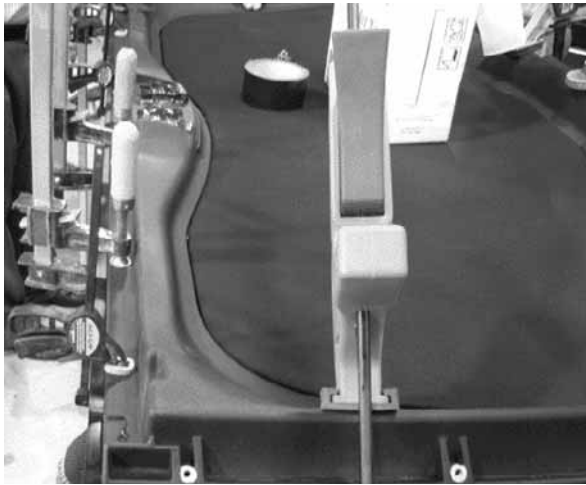

1832863

2. Place a rubber-coated clamp (or equivalent) 102 mm (4 in) on either side of the separation. Ensure that a clamp is installed every 152 mm (6 in) along the gap or separation area. Refer to the illustration for clamp position.

Important: If a bead of urethane is not applied to the gap or separation area, foam will ooze out of the gap or separation area during the foam adhesive injection process.

3. Apply a bead of urethane to the inner and outer edge of any area of the roof panel with a gap or separation.



1832882

4. Prepare the roof panel for the foam adhesive injection.

Important: Use tape with strong adhesion. It is difficult to clean the foam off of visible surfaces. Ensure that the tape covers holes 1, 2, and 3.

- 4.1 Cut four pieces of tape to cover holes 1, 2, and 3. Tape length: 76 mm (3 in); Tape width: 76 mm (3 in).
- 4.2 Place the tape near the roof panel holes 1, 2, and 3. Two pieces of tape are required for roof panel hole #1.

- 4.3 Insert the two removed bolts from the rear center attachment into the holes (finger tight) until the washer is touching the roof inner panel. This is to prevent foam from filling the location where the bolts are to be when the roof is reinstalled.

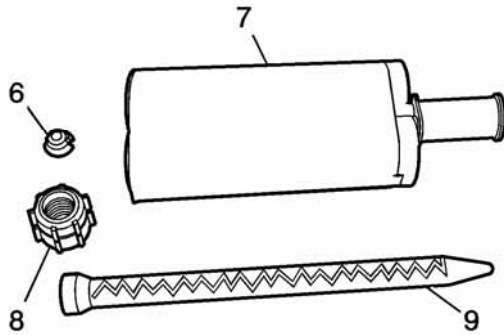

- 6 Reducer
- 7 Two-Part Foam Cartridge
- 8 Nut
- 9 Mixer Nozzle

1748413

- 4.4 Prepare one cartridge.

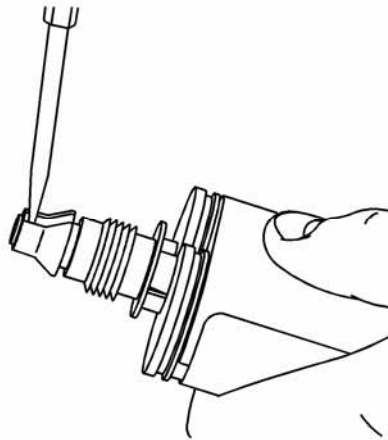

1748414

- 4.5 Remove the top plug. Insert a screwdriver into the end and rock it back and forth.

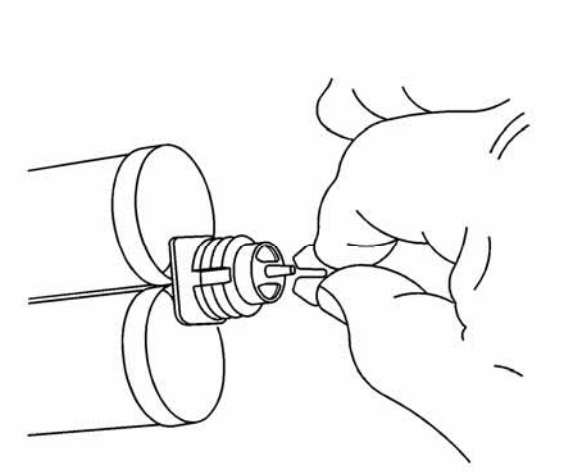

1748416

4.6 Install a reducer into the cartridge

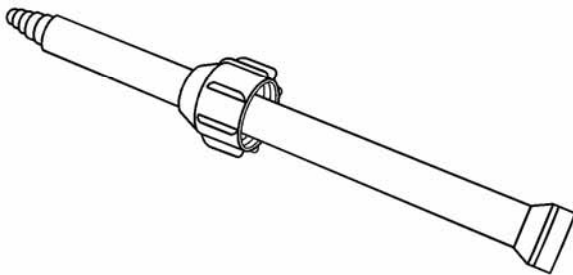

1748417

4.7 Insert a mixer nozzle through a nut.

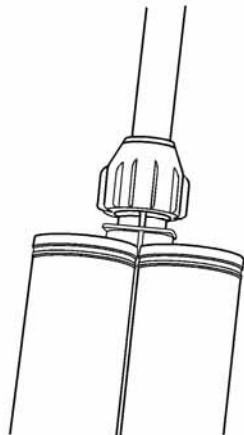

1748419

4.8 Install the nozzle onto the cartridge.

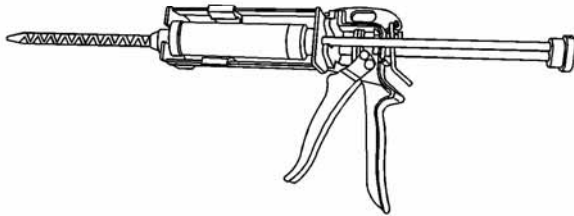

1748420

4.9 Install the cartridge nozzle assembly to the BO 48206 applicator gun.



1832882

Important: This is a two-part foam product that expands and sets very quickly. Once the mixing begins, the foam will be set in approximately 15 seconds. It is recommended that technicians wear disposable gloves while working with the foam adhesive. Steps 10, 12, and 14 must be performed within approximately 15 seconds from start to finish.

5. Place one piece of tape over the bottom (smaller) hole (1) before injecting foam into the hole (1).
6. Inject six pumps of adhesive foam into the rear slot or top hole (1) of the roof panel.
7. Tape over the top slot hole (1) to keep the foam from coming out.
8. Inject four pumps of adhesive foam into the outboard (left) side of the hole (2) and then turn the applicator to the inboard (right) side of the hole (2) and inject four pumps of adhesive foam into the hole (2).
9. Tape over the hole (2) to keep the foam from coming out.
10. Inject four pumps of adhesive foam into the outboard (left) side of the hole (3) and then turn the applicator to the inboard (right) side of the hole (3) and inject four pumps of adhesive foam into the hole (3).
11. Tape over the hole (3) to keep the foam from coming out.
12. Wait 60 seconds for the foam to set.

13. Remove the tape from holes 1, 2, and 3.
14. Look for any areas where the foam may have leaked out between the frame and the composite panel. Clean the areas where foam leaked out between the frame and the composite panel. Apply a bead of urethane to the inner and outer edge of any area of the roof panel where foam was present.
15. Inspect the roof panel bolt holes for foam or debris. Clean the bolt hole threads with a tap.



1832871

16. Install the roof panel shims to the roof panel assembly contact points. Verify fit of roof panel. Adjust shims as required.

Notice: Discard the old roof panel fasteners and install new roof panel fasteners. Clean the 10 roof panel thread holes with a tap before installing the new roof panel fasteners to avoid damaging the bolt hole or fastener. This is required to clean the adhesive that was left from the original bolts on the threaded attachment holes.

17. Install the roof panel to the vehicle.

Tighten

Tighten the roof panel bolts to 9 N·m (80 lb in).



1832869

18. Install the headliner in the vehicle.

- 18.1 Slide the headliner through the rear hatch and place it into position.
- 18.2 Align the headliner in the following locations
 - Windshield side garnish moldings
 - Sun visor mounting bezel holes and sun visor clamp holes
 - Rear roof bow trim panel area
19. Connect the rear view mirror electrical connector. Refer to the *Rear View Mirror Replacement* procedure in SI.
20. Install the windshield side garnish moldings. Refer to the *Windshield Side Garnish Molding Replacement* procedure in SI.
21. Install the driver and passenger side sun visor and sun visor clamp. Refer to the *Sun Shade Replacement* procedure in SI.
22. Install the rear roof bow trim panel. Refer to the *Rear Roof Bow Trim Panel Replacement* procedure in SI.

Inspection Procedure - Standard Coupe (non Z06)

Tools Required

- BO 48206 Two-Part Applicator Gun

1. Remove the roof panel from the vehicle.

Notice: Be sure to protect the painted surface of the panel from damage.

2. With the painted surface down, support the roof panel horizontally on a glass stand, bench, or other suitable area.
3. Lift the edge of the headliner in the areas indicated for inspection in the next step.

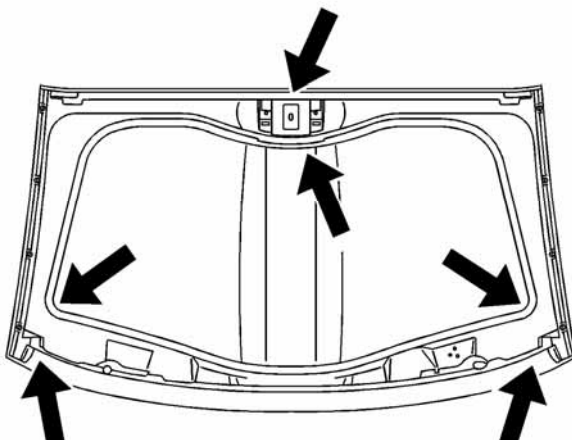

1748402

4. Inspect for proper adhesion by inserting a 0.254 mm (.010 in) feeler gage between the panel and the frame. Particular attention should be paid to the areas around the rear latch and the front corners. If the feeler gage fits between the panel and the frame, and the depth is 19.05 mm (.750 in) or greater, the roof panel has some degree of separation.
 - If the feeler gage does not identify any area of the roof panel with separation, proceed to Step 5.

- If less than 75 percent of the roof panel is separated from the frame, prepare the roof panel for the foam adhesive injection procedure. Refer to the section titled, *Roof Panel Preparation for Roof Panels with Separation*. This is a temporary repair that will prevent the separation of the roof panel. Submit the claim using labor code T5641, which will not close the program in GMVIS. When the roof panel is available, install the new roof panel and submit the claim using the appropriate V labor code, which will close the program in GMVIS.

Important: Inspect all roof panels, including new roof panels, to determine if the foam fill procedure has been completed. Perform the foam adhesive injection procedure on all new roof panels that have not been foam filled. Perform Steps 5-24 after removing the original roof panel and following the SI procedures listed in the table below.

- If more than 75 percent of the roof panel is separated from the frame, replace the roof panel. The SI procedures below may be used.

Description	SI Document #
Headliner Replacement - Roof Lift Off Panel	1508849
Roof Lift Off Panel Rear Latch Replacement	1582986
Roof Lift Off Panel Front Latch Handle Replacement	1582355
Roof Lift Off Panel Molding Replacement	656617
Roof Lift Off Panel Rear Locator Pin Replacement	656610
Roof Lift Off Panel Adjustment	815143

Roof Panel Preparation for Roof Panels with Separation

1. Mark gaps or separation of the roof panel with tape.

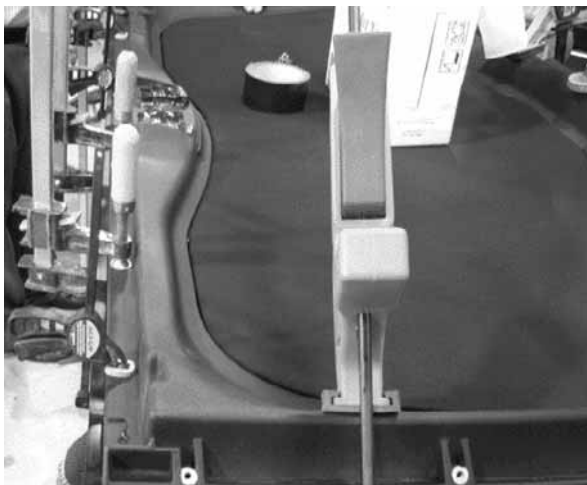

1832863

2. Place a rubber-coated clamp (or equivalent) 102 mm (4 in) on either side of the separation. Ensure a clamp is installed every 152 mm (6 in) along the gap or separation area. Refer to the illustration for clamp position.

Important: If a bead of urethane is not applied to the gap or separation area, foam will ooze out of the gap or separation area during the foam adhesive injection process.

3. Add a bead of urethane to the inner and outer edge of any area of the roof panel with a gap or separation.
4. Proceed to Step 5.

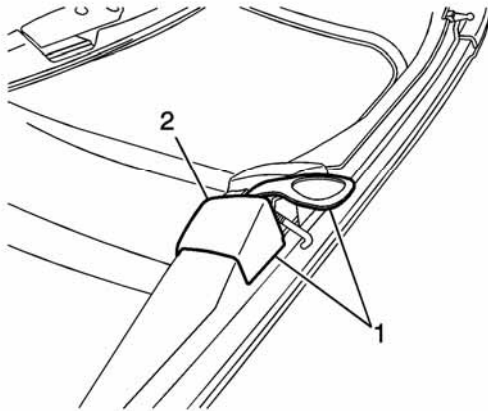

1748403

5. Remove the rear latch trim screws (1) and the trim (2).

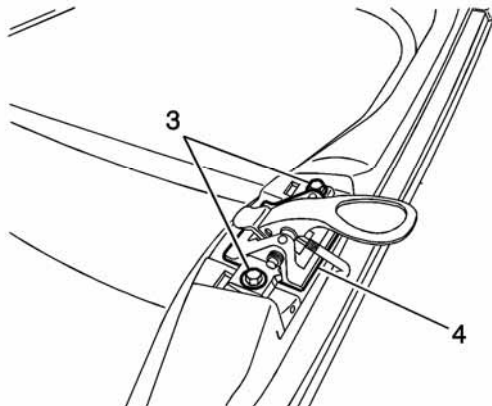

1748406

6. Remove the rear latch attaching bolts (3) and the rear latch assembly (4).

Important: Perform Step 7 if no gap or separation was identified in Step 4. Proceed to Step 8 if a gap or separation was identified in Step 4. If installing a new roof panel, proceed to Step 8.

7. Inspect the area underneath the latch for foam.

- If foam is present, the foam adhesive injection process has been completed. No further action is required.
 - If foam is not present, proceed to Step 8.
8. Install the rear latch attaching bolts (3) to the frame.

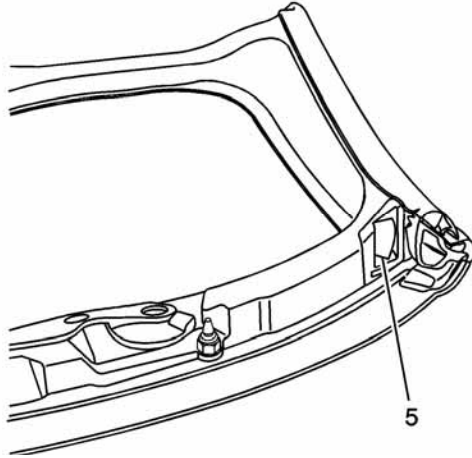

1748407

9. Remove the front corner brackets (5)

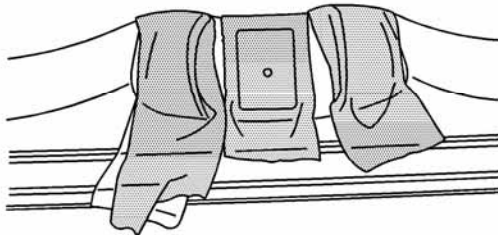

1748409

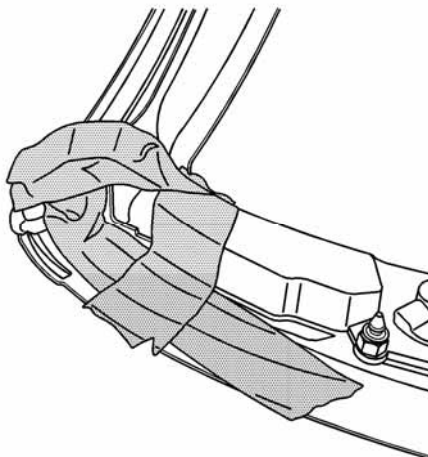

1748410

10. Tape off the rear latch and the front bracket areas.

Important: Cover the area completely with tape that has strong adhesion. It is difficult to clean the foam off of visible surfaces.

11. Using a pen or small knife, cut holes in the tape to inject foam.

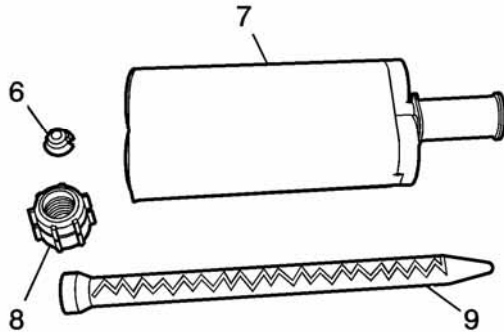

- 10 Reducer
- 11 Two-Part Foam Cartridge
- 12 Nut
- 13 Mixer Nozzle

1748413

Important: This is a two-part foam product that expands and sets very quickly. Once the mixing begins, the foam will be set in approximately 15 seconds. It is recommended that technicians wear disposable gloves while working with foam.

12. Prepare a cartridge.

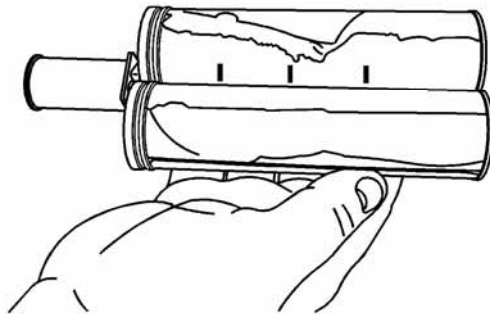

1748423

- 12.1 Remove a portion of the label.
- 12.2 Measure the length of the tubes containing the foam product. Divide the length and mark the cartridge into four equal parts.

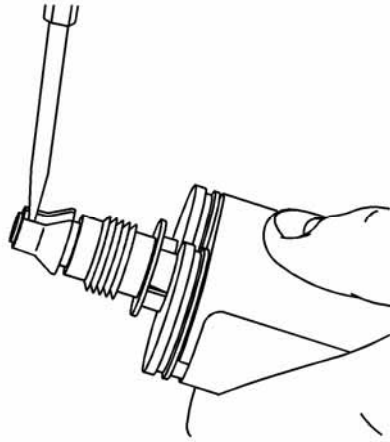

1748414

12.3 Remove the top plug. Insert a screwdriver into the end and rock it back and forth.

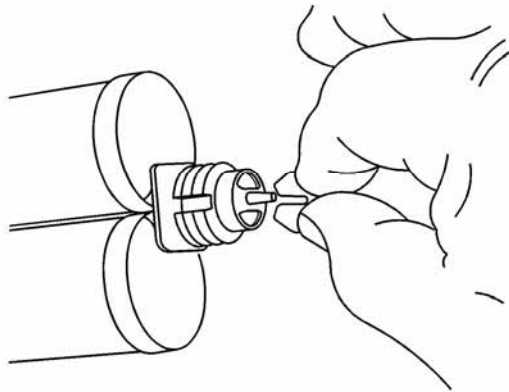

1748416

12.4 Install a reducer into the cartridge.

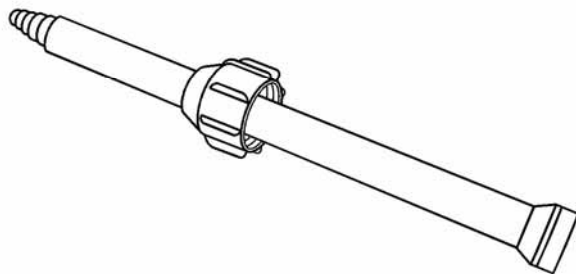

1748417

12.5 Insert a mixer nozzle through a nut.

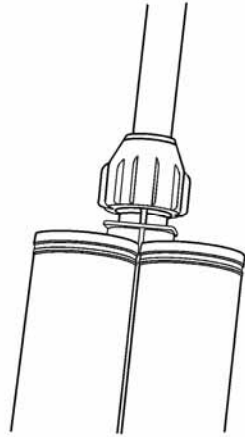

1748419

12.6 Install the nozzle onto the cartridge.

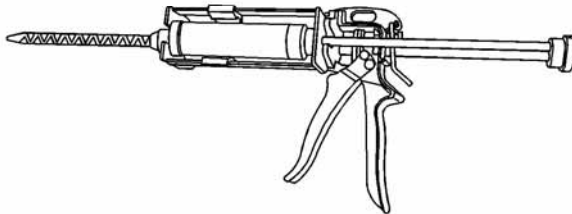

1748420

12.7 Install the cartridge nozzle assembly to the BO 48206 applicator gun.

12.8 Prepare a piece of tape to cover the hole in each front cover after the foam is injected.

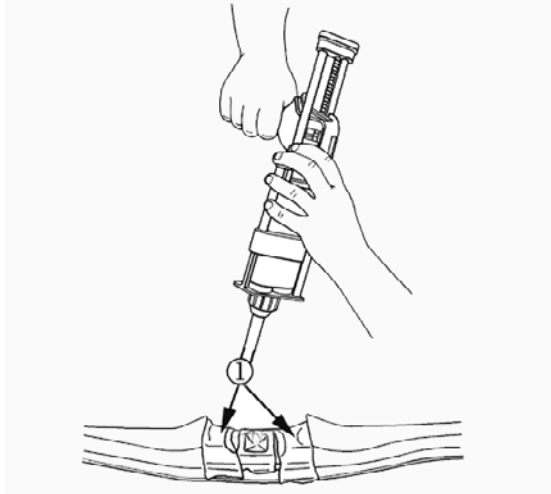

1832883

Important: The following steps must be performed within approximately 15 seconds from start to finish.

13. Inject one half of the cartridge of foam into the right rear latch area (1) of the panel and the other half of the cartridge into the left latch area (1) of the panel.
14. Tape over the holes to keep the foam from coming out.
15. Prepare a second cartridge.

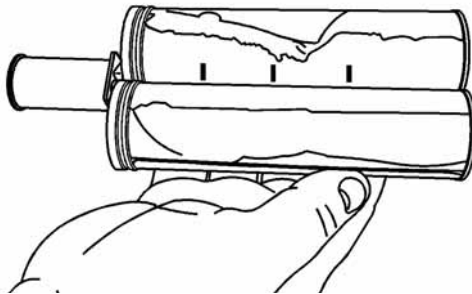

1748423

- 15.1 Remove a portion of the label.
- 15.2 Measure the length of the tubes containing the foam product. Divide the length and mark the cartridge into four equal parts.
- 15.3 Remove the top plug.
- 15.4 Install a reducer into the cartridge.
- 15.5 Insert a mixer nozzle through a nut.
- 15.6 Install the nozzle onto the cartridge.
- 15.7 Install the cartridge nozzle assembly to the BO 48206 applicator gun.
- 15.8 Prepare a piece of tape to cover the hole in each front corner after the foam is injected.

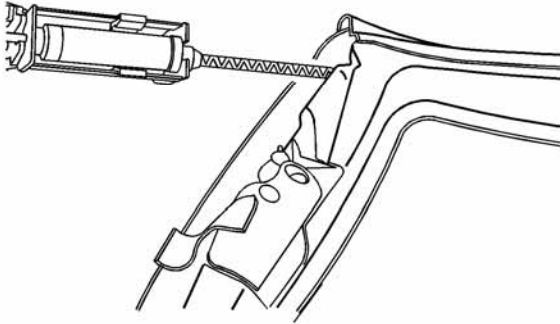

1748425

Important: The following steps must be performed within approximately 15 seconds from start to finish.

16. Insert the cartridge approximately 25 mm (1 in) into the hole.

Important: Use one quarter of the cartridge in each of the next four steps.

- 16.1 While watching the cartridge, inject one quarter of the foam in one front corner, pointing front to back.

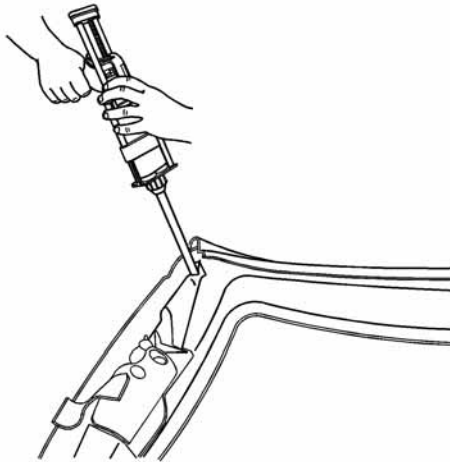

1748426

- 16.2 In the same corner, turn the applicator and inject one quarter of the foam, pointing the applicator from side to side.
- 16.3 Tape the hole closed.
- 16.4 Repeat for the other front corner.
17. Wait 60 seconds for the foam to set.
18. Remove all of the tape.
19. Look for any areas where the foam may have leaked out between the frame and the composite panel. If required, clean the area where foam leaked out between the frame and the composite panel. Apply a bead of urethane around the entire perimeter of the roof panel to improve the appearance of the roof panel edge. Apply the bead of urethane between the frame and composite panel.

20. Install the front corner brackets. A sharp knife or small screwdriver may be needed to remove just enough foam to install the brackets.
21. Remove the latch bolts.
22. Install the latch and bolts. A sharp knife or small screwdriver may be needed to remove just enough foam to install the latch and latch trim cover.
23. Install the rear latch trim cover and screws.
24. Install a new headliner, if required.
25. Install the top to the vehicle.

COURTESY TRANSPORTATION

The General Motors Courtesy Transportation program is intended to minimize customer inconvenience when a vehicle requires a repair that is covered by the New Vehicle Limited Warranty. The availability of courtesy transportation to customers whose vehicles are within the warranty coverage period and involved in a product program is very important in maintaining customer satisfaction. Dealers are to ensure that these customers understand that shuttle service or some other form of courtesy transportation is available and will be provided at no charge. Dealers should refer to the General Motors Service Policies and Procedures Manual for Courtesy Transportation guidelines.

CLAIM INFORMATION

Submit a Product Claim with the information indicated below:

REPAIR PERFORMED	PART COUNT	PART NO.	PARTS ALLOW	CC-FC	LABOR OP	LABOR HOURS	NET ITEM
Inspect Roof Panel - No Further Action Req'd. (Foam Adhesive Filled Panel) - Std Coupe - Z06	0	N/A	N/A	MA-96	V1485	0.2 1.0	N/A
Inspect & Inject Foam Adhesive (panel had no adhesive separation) - Std Coupe - Z06	2 2	---	*	MA-96	V1442	0.4 1.2	**
Inspect & Inject Foam Adhesive (panel had less than 75% adhesive separation) - Std Coupe - Z06	2 2	---	*		T5641	0.7 1.5	**
Inspect & Replace Roof Panel & Headliner (includes 1.5 hrs for paint & mix time) - Std Coupe - Z06	1-2 2	---	***	MA-96	V1482	1.8 2.6	****
Add: Inject Foam Adhesive	2		*			0.4	**
Courtesy Transportation for vehicles within the New Vehicle Limited Warranty (US & Canadian GM Dealers)	N/A	N/A	N/A	MA-96	*****	N/A	*****

- * The "Parts Allowance" should be the sum total of the current GMSPO Dealer net price plus applicable Mark-Up or Landed Cost Mark-Up (for Export) for the two foam adhesive kits for the standard coupe, or one adhesive kit and bolt assembly for the Z06 vehicles..
- ** The amount identified in the "Net Item" column should represent the actual sum total of the current GMSPO Dealer net price plus applicable Mark-Up or Landed Cost Mark-Up (for Export) for the tape if needed to perform the required repairs, not to exceed \$0.50 USD, \$0.58 CAD.
- *** The "Parts Allowance" should be the sum total of the current GMSPO Dealer net price plus applicable Mark-Up or Landed Cost Mark-Up (for Export) for the roof panel, and if required, the headliner for the standard coupe, or the roof panel and bolt assembly for the Z06 vehicles.
- **** The amount identified in the "Net Item" column should represent the actual sum total of the current GMSPO Dealer net price plus applicable Mark-Up or Landed Cost Mark-Up (for Export) for the paint allowance GI (\$42.29 USD, \$48.03 CAD).
- ***** Submit courtesy transportation using normal labor operations for courtesy transportation as indicated in the GM Service Policies and Procedures Manual for vehicles within the New Vehicle Limited Warranty.

***** The amount identified in the "Net Item" column should represent the actual dollar amount for courtesy transportation.

CUSTOMER NOTIFICATION – For US and Canada

General Motors will notify customers of this program on their vehicle (see copy of customer letter included with this bulletin).

CUSTOMER NOTIFICATION – For Export

Letters will be sent to known owners of record located within areas covered by the US National Traffic and Motor Vehicle Safety Act. For owners outside these areas, dealers should notify customers using the attached sample letter.

DEALER PROGRAM RESPONSIBILITY - All

All unsold new vehicles in dealers' possession and subject to this program must be held and inspected/repaired per the service procedure of this program bulletin before customers take possession of these vehicles.

Dealers are to service all vehicles subject to this program at no charge to customers, regardless of mileage, age of vehicle, or ownership, through March 31, 2007.

Customers who have recently purchased vehicles sold from your vehicle inventory, and for which there is no customer information indicated on the dealer listing, are to be contacted by the dealer. Arrangements are to be made to make the required correction according to the instructions contained in this bulletin. A copy of the customer letter is provided in this bulletin for your use in contacting customers. Program follow-up cards should not be used for this purpose, since the customer may not as yet have received the notification letter.

In summary, whenever a vehicle subject to this program enters your vehicle inventory, or is in your dealership for service prior to March 31, 2007, you must take the steps necessary to be sure the program correction has been made before selling or releasing the vehicle.



February 2006

Dear General Motors Customer:

This notice is sent to inform you that Chevrolet is conducting a customer satisfaction program that affects certain 2005 and 2006 model year vehicles that are equipped with a painted roof.

We have learned that the painted roof panel may separate from its frame in some areas if it is exposed to stresses along with high temperature and humidity. The occupants of the vehicle may notice one or more of these symptoms: a snapping noise when driving over bumps, wind noise, poor roof panel fit, roof panel movement/bounce when a door or hatch is closed, or a water leak in the headliner.

What We Will Do: To prevent this condition from occurring, your Chevrolet dealer will inspect the roof panel for proper adhesion, and if necessary, inject adhesive foam to seal the panel. In some cases, the roof panel may require replacement. This service will be performed for you at **no charge until March 31, 2007.**

What You Should Do: To limit any possible inconvenience, we recommend that you contact your dealer as soon as possible to schedule an appointment for this repair. By scheduling an appointment, your dealer can ensure that the necessary parts will be available on your scheduled appointment date.

Customer Reply Form: The enclosed customer reply form identifies your vehicle. Presentation of this form to your dealer will assist in making the necessary correction in the shortest possible time. If you no longer own this vehicle, please let us know by completing the form and mailing it back to us.

If you have any questions or need any assistance, just contact your dealer or the appropriate Customer Assistance Center at the number listed below. The Customer Assistance Center's hours of operation are from 8:00 AM to 11:00 PM, EST, Monday through Friday.

Division	Number	Text Telephones (TTY)
Chevrolet	1-800-630-2438	1-800-833-2438
Guam	1-671-648-8650	
Puerto Rico – English	1-800-496-9992	
Puerto Rico – Español	1-800-496-9993	
Virgin Islands	1-800-496-9994	

Courtesy Transportation: If your vehicle is within the New Vehicle Limited Warranty your dealer may provide you with shuttle service or some other form of courtesy transportation while your vehicle is at the dealership for this repair. Please refer to your Owner's Manual and your dealer for details on Courtesy Transportation.

We sincerely regret any inconvenience or concern that this situation may cause you. We want you to know that we will do our best, throughout your ownership experience, to ensure that your Chevrolet Corvette provides you many miles of enjoyable driving.

General Motors Corporation

Enclosure
05112